

96 press-in contacts

☒ = position with contact

☐ = position without contact

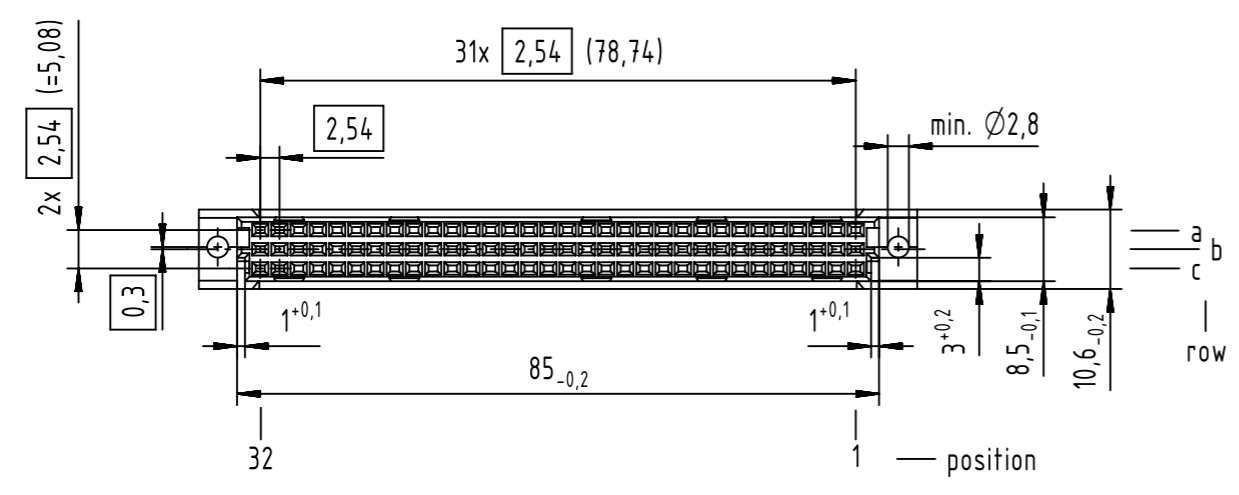
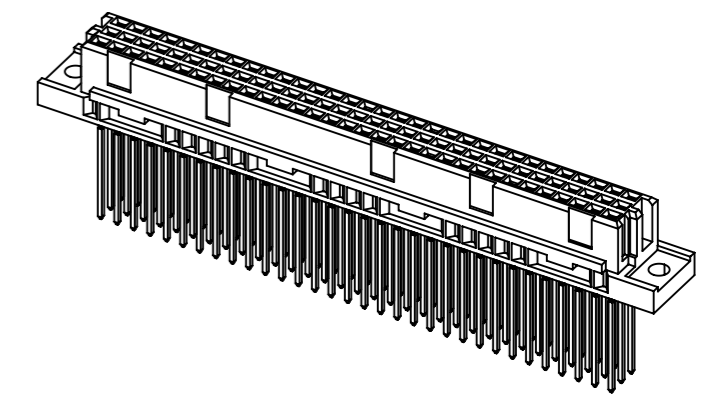
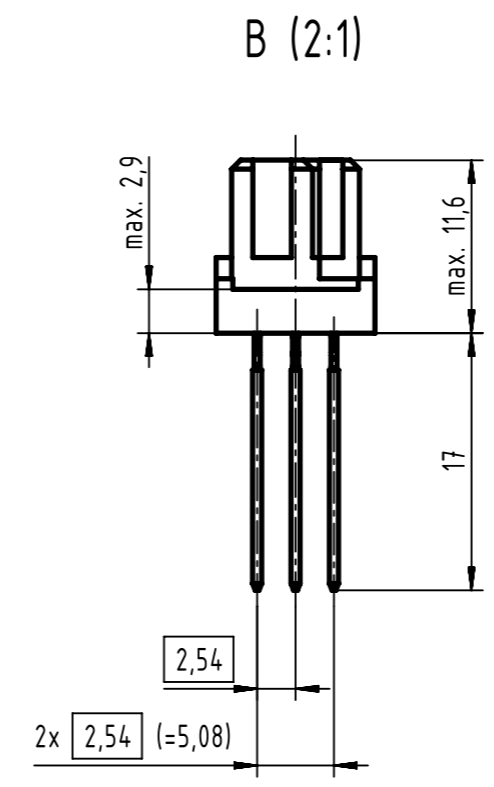
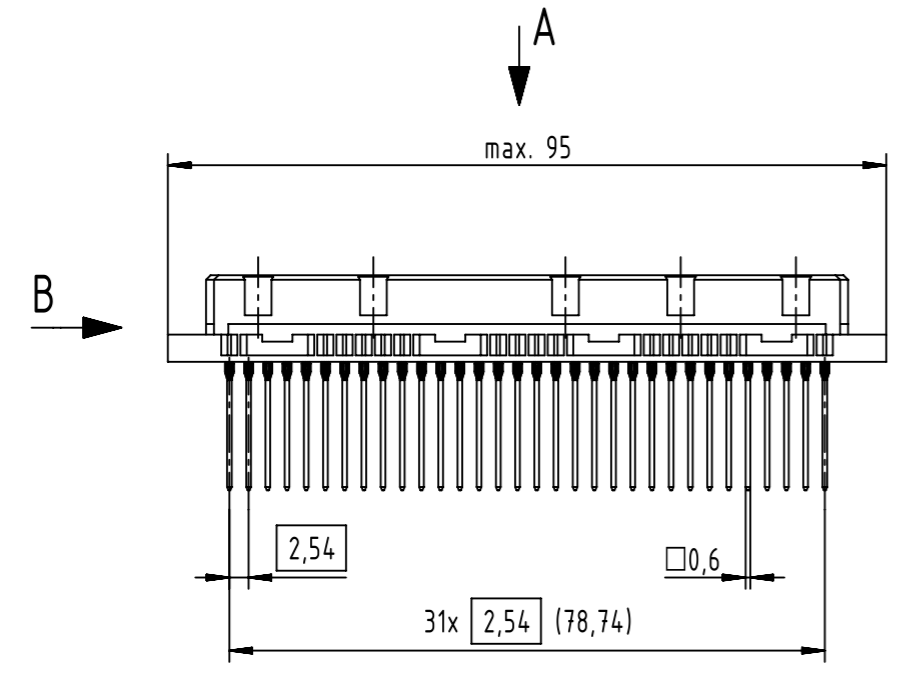

(1) recommended configuration of plated holes and further information see: DS 0903210007

09 03 296 2852 252	1
part no.	performance level (1)

	All Dimensions in mm Original Size DIN A3		Scale 1:1	Free size tol.		Ref.	
	All rights reserved Department EC PD - DE		Created by STORCK	Inspected by LEHNERT	Standardisation HOFFMANN	Date 2017-01-19	State Final Release
HARTING Electronics GmbH D-32339 Espelkamp		Title DIN Signal type C female press-in 17.0 96-pole			Doc-Key / ECM-Nr. 100678522/UGD/000/B 500000114120		Rev. B
		Type TB	Number 0903296X852252		Page 1/1		